



**Features**

- Flame-retardant polypropylene case and cover compliant with UL94 V-0 with and Oxygen Limiting index of greater than 28%.
- Gas recombination greater than 99%.
- Operates at a low internal pressure.
- Never needs watering, minimal maintenance.
- 99.7% pure lead calcium grids.
- Shock absorbent thick wall construction.
- Cold forged non-porous terminal bushings, eliminate post leakage.
- Thermally welded case to cover bond, eliminates both acid and electrical leaks.
- Over-sized, through the partition inter-cell welds provide low resistance connections, with minimal power loss.
- Each cell has a low pressure safety release venting system, recognized per U.L. 924.
- Measured high vacuum acid fill, reduces electrical variability between cells.
- Inter-unit busbars and terminal covers
- 100% recyclable materials.

**Options**

- Custom inter-connecting battery cables.

**VALVE REGULATED  
LEAD ACID BATTERY (V.R.L.A.)**



**ABSORBED GLASS MAT  
TECHNOLOGY (A.G.M.)**



**10 YEAR DESIGN FOR UPS AND  
STANDBY APPLICATIONS**



**Specifications**

Cells per unit	6
Nominal voltage	12
Terminal type	Copper insert 1/4"
Maximum discharge current	600 amps
Short circuit current	3366 amps
Impedance @ 77°F 25°C	4.1 milliohms
Weight lbs / kgs	74 / 33.5
Electrolyte (S.G.)	1.300
Capacity @ 77°F (25°C) to 1.75 V.P.C.	91.0 AH (20 hrs) 82 AH (8 hrs)
Ideal operating temperature range	+68°F (+20°C) to +77°F (+25°C)
Extended operating temperature range	Discharge: -40°F (-40°C) to +140°F (+60°C) Charge: -40°F (-40°C) to +122°F (+50°C)
Float Voltage	13.5 to 13.8 @ 77°F (25°C)
Maximum charging current	C/4 amperes at 100% discharge Unlimited at partial discharge.
AC ripple from charging source	1.5% peak to peak of float charge voltage
Storage	6 months at 77°F (25°C)

**No transport restrictions**

- Surface transport. Classified as non-hazardous material as relates to DOT-CFR Title 49 part 171-189.
- Maritime transport. Non hazardous as per IMDG amendment 27.
- Air transport. Complies with IATA / ICAO, special provision A67.

**DISCHARGE SPECIFICATIONS**

Constant power ratings, Watts per battery @ 77°F (25°C) in minutes

Final V.P.C.	5	10	15	20	30	40	45	50	60	90
1.60	3371	2501	1930	1579	1170	939	865	791	688	502
1.67	3257	2454	1909	1564	1161	933	860	787	685	501
1.70	3207	2436	1896	1555	1157	930	857	785	684	497
1.75	3041	2293	1827	1525	1146	922	850	778	678	496

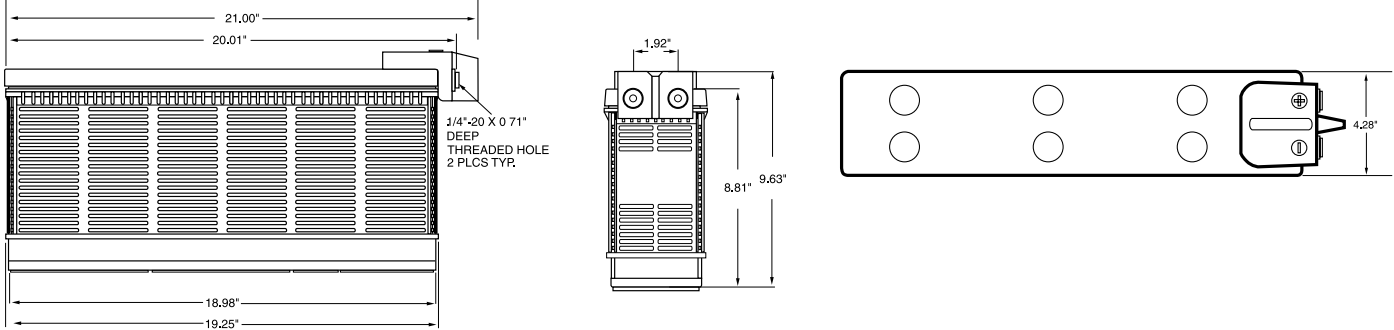

POWER BATTERY offers an extensive line of pre-wired and fused battery cabinets complete with UL and CUL approval. Standard and custom DC voltages complete with breakers and chargers are available.

Battery Cabinet Systems (pre-wired with SLF-12105 batteries)					
Battery cabinet model	Maximum # of batteries	Dimensions			
		inches / millimeters			Weight bs/kgs
		W	D	H	
CZ3	24	42.0/1067	31.5/800	50.3/1278	3852/1751
CZ6	32	42.0/1067	31.5/800	61.3/1557	5236/2380
CZ4	40	42.0/1067	31.5/800	72.3/1837	6320/2873

Modular Stacking System					
Rack model	Qty	W	D	H	lbs / kgs
EZ1	8	20.3/516	23.0/584	22.5/572	1254/570
Open front modular stacking system. Can be stacked 4 high					

Constant current ratings, Amperes @ 77°F (25°C) in hours										
Final V.P.C.	1	2	3	4	5	6	8	10	12	24
1.75	57.1	33.2	24.1	19.0	15.6	13.3	10.3	8.40	7.17	3.87
1.80	56.3	32.9	23.9	18.6	15.4	13.1	10.2	8.35	7.11	3.82
1.85	54.1	32.0	23.1	18.0	14.9	12.7	9.80	8.07	6.86	3.69
1.90	49.7	29.9	21.7	17.0	14.0	11.9	9.10	7.46	6.28	3.41

1226-2-0205  
**U.S.A.**  
**Power Battery Company, Inc.**  
 25 McLean Blvd.  
 Paterson, N.J. 07514-1507  
 Phone: (973) 523-8630  
 Fax: (973) 523-3023  
 E-mail: sales@powbat.com  
 Website www.powerbattery.com

**CANADA**  
**Power Battery (Iberville) Ltd.**  
 770 Thomas Ave.  
 Iberville, Québec, J2X 5E7  
 Phone: (450) 346-3273  
 Fax: (450) 346-8003  
 E-mail: powerbat@sympatico.ca  
 Website: www.powerbattery.com

**UK**  
**Power Batteries Ltd.**  
 Premier Way, Abbey Park Industrial Estate  
 Romsey, Hampshire, SO51 9AQ  
 Phone: +44 (0)1794 835900  
 Fax: +44 (0)1794 835910  
 E-mail: sales@powbat.co.uk  
 Website: www.powbat.co.uk

**ITALY**  
**Power Battery Srl**  
 Via Locatelli 105  
 20046 Biassono MI - ITALY  
 Phone: +(39) 039 2324571  
 Fax: +(39) 039 2499200  
 E-mail: calberti@powbat.co.uk  
 Website: www.powbat.co.uk

**CHINA**  
**Power Battery (PACIFIC RIM) LTD.**  
 Unit 1, 23/floor, Wealthy Plaza  
 138 Sau Kei Wan Road  
 Sai Wan Ho, Hong Kong  
 Phone: ++(852) 2-560-2222  
 Fax: ++(852) 2-967-8157  
 E-mail: bplhk@netvigator.com  
 Website: www.powerbattery.com